

### Type A Sign: Major Trailhead Sign

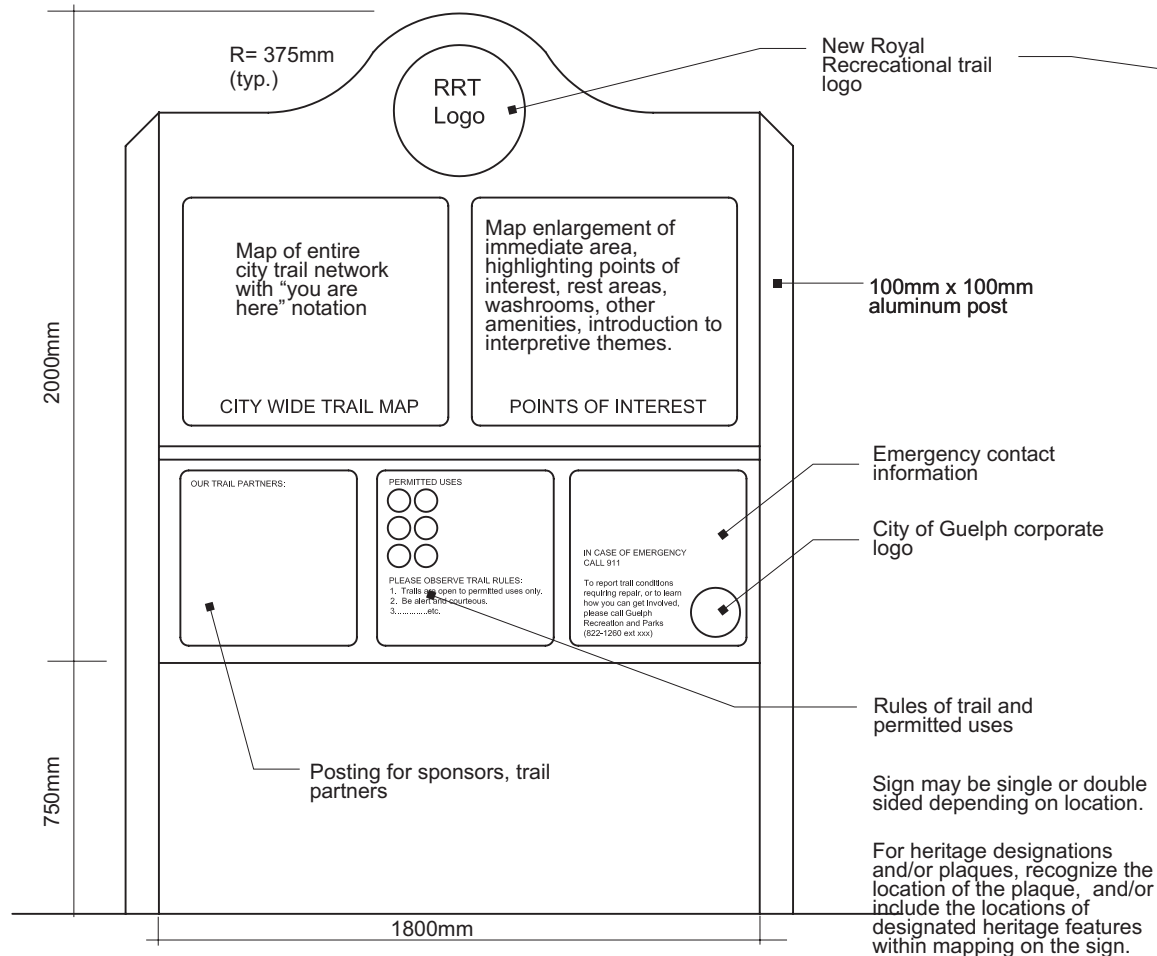

### Type C Sign: Directional Sign

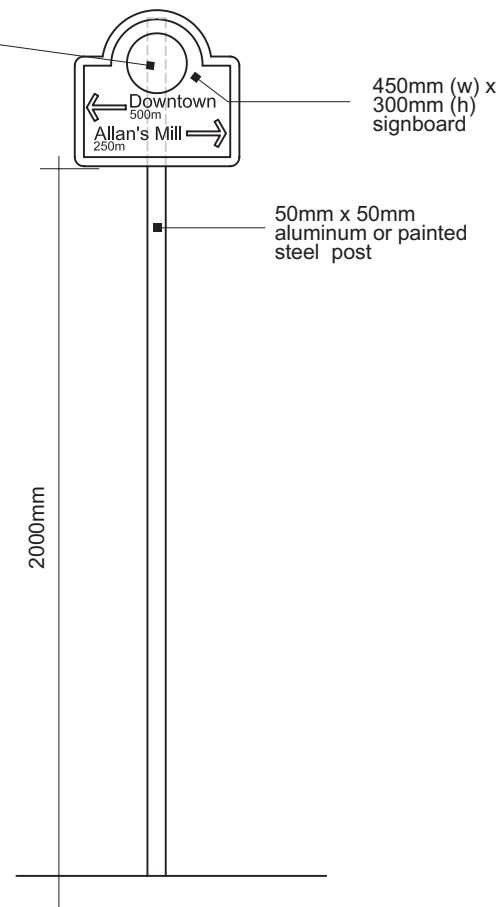

### Type D Sign: Trail Marker

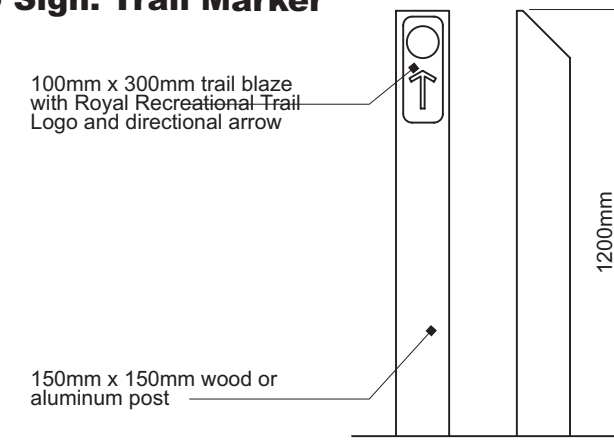

#### Sign Placement

The following chart provides some guidance regarding the frequency with which each sign type should be placed throughout the trail system. It is important to note that this chart is intended as guideline only and that signage must be considered on a site-specific basis

Sign Type	Frequency /Typical Location	Other Comments
<b>General Sign Types</b>		
Type A Sign (Major Trailhead Sign)	At every major trailhead. (Refer to network map for suggested locations of major staging areas/trailheads).	Must be considered as part of an integrated design for the trailhead/staging area
Type B Sign (Minor Trailhead Sign)	At every minor trailhead/staging area. (Refer to network map for suggested locations of major staging areas/trailheads).	Must be considered as part of an integrated design for the trailhead/staging area
Type C Sign (Directional Sign)	Where main trails intersect with other main trails, where main trails intersect with minor trails, at connecting links to nearby communities.	
Type D Sign (Trail Marker)	At regular intervals along the trail system (500m for rural trails with motorized uses, 250m for urban/town trails where walkers are a major user group). At trail directional change points	
Type E Sign (Interpretive Sign)	Located within view of features to be interpreted.	Frequency dependent upon number of features to be interpreted and anticipated major trail user mode. Consider 1 sign for every 20 minutes of active trail use (20-minute walk, 20-minute ride) for a dedicated interpretive trail. For trails where sporadic features are to be interpreted, signs should be located at feature sites.
<b>Other Signs</b>		
Regulatory sign	As required throughout the system to inform users of maximum rate of travel, hazards etc.	Use sign types recognized by Ministry of Transportation and Transportation Association of Canada. To be placed in advance of feature/point. Distance from sign to feature is determined by design speed of trail to allow users sufficient reaction time (minimum 30m is recommended).
Trail Etiquette	At each trailhead, access point or roadway crossing.	Can be stand alone sign or can be incorporated into trailhead signs.

### Type E Sign: Interpretive Sign

General Note: Background colour for signing may be consistent across the entire city (entire trail system), or it may be changed in different areas of the city relating to different themes for various parts of the trail system.

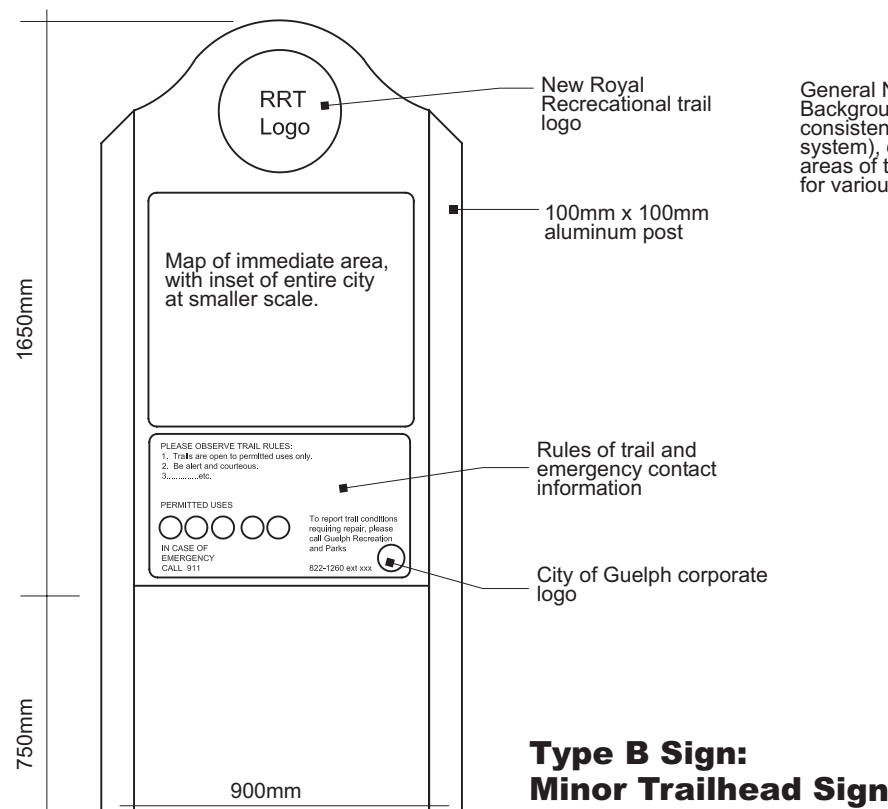
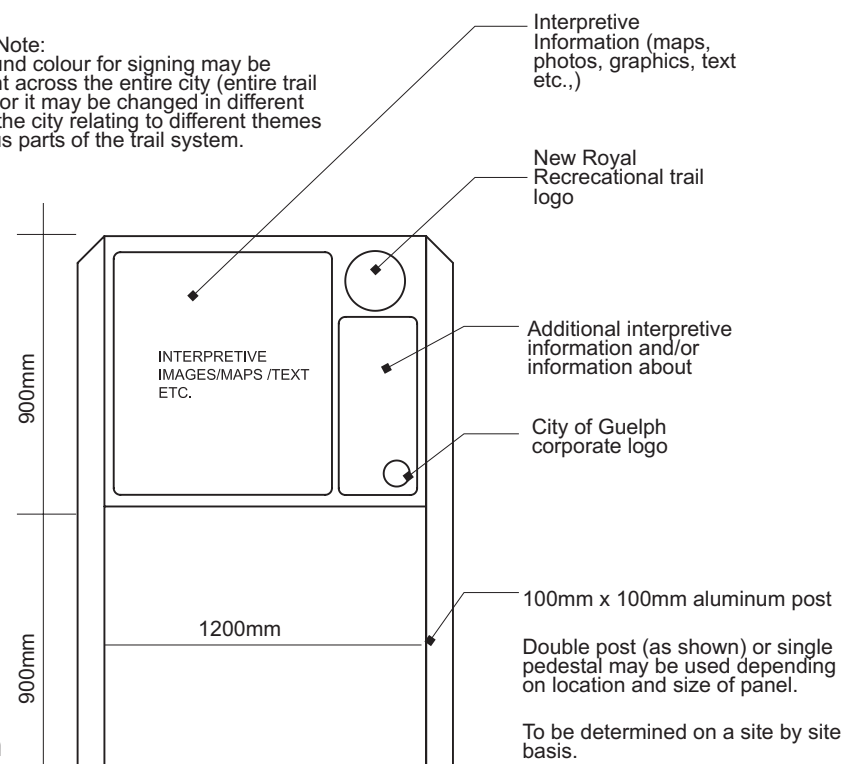

FILE: G0289/Report/Figures/Figure 17.GDR

Fig. 5-23 Trail Signs